

BONENG

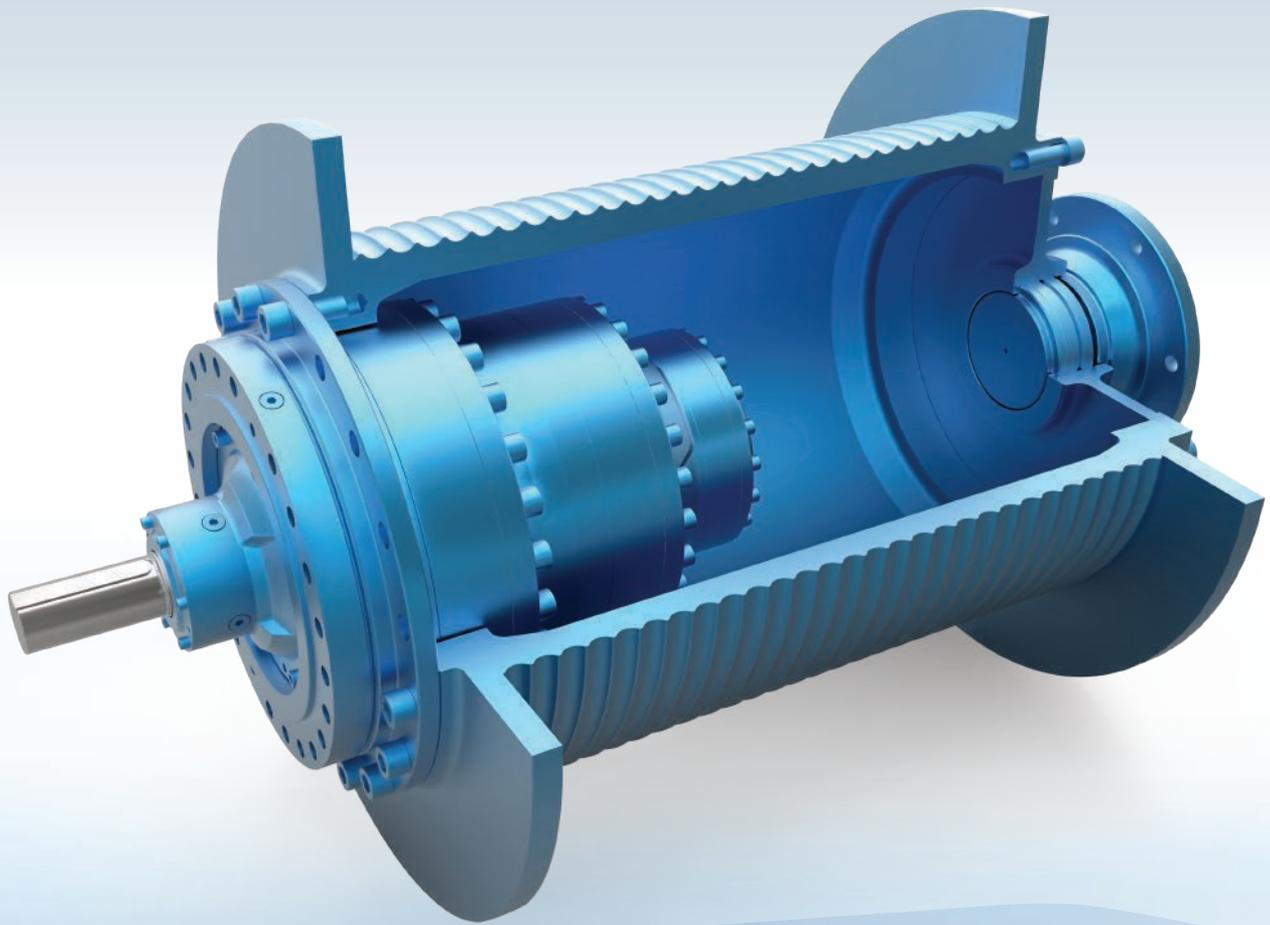

博能 PW行星内藏式卷扬齿轮箱
PW Winch Gearbox

07 / 2017

PW行星内藏式卷扬齿轮箱

PW winch gearbox

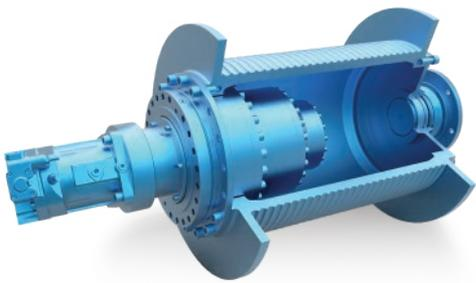

- ◆ PW行星内藏式卷扬齿轮箱是卷扬机构的理想驱动装置。结构紧凑，可直接安装于卷筒内部，节省空间，特别是在空间窄小的情况下，它是更经济的解决方案。在繁重工作条件和恶劣环境下能提供卓越的品质和性能，并经过过考验。
- ◆ 太阳轮、行星轮均采用优质合金钢渗碳淬火处理，内齿圈采用优质合金钢表面硬化处理，所有齿轮均磨齿加工。
- ◆ 行星架和内齿圈连接法兰均采用球墨铸铁材料，且均通过计算机模拟变形和应力分析等优化设计。
- ◆ 所有轴承采用知名品牌，轴承系统承载能力高，安全裕度大。
- ◆ 输入、输出采用径向骨架油封及V型密封，在复杂和恶劣的工作环境中具有更高的安全性和更长的使用寿命。
- ◆ 高度的模块化设计，批量生产更加经济，有效提高供货速度。
- ◆ 两级、三级和四级行星齿轮传动设计，速比覆盖范围广。
- ◆ 运转噪音低，传动效率高，使用寿命长。
- ◆ 安装简单，维护方便。
- ◆ PW winch gearbox is the perfect driven device for hoisting winches. Compact dimensions is useful to assemble the PW winch gearbox in the drum and save the space. Especially in the confined space conditions, it is the economic solutions. Boneng PW winch gearbox have proved highly successful under extreme bad operating conditions.
- ◆ Sun and planet wheels material is excellent alloy steel and processed by carburization and quenching. Internal gear wheel material is excellent alloy steel and processed by hardening. All gears grinding.
- ◆ The connection flange of planet carrier and internal gear wheel are made of ductile graphite iron. Optimal design through the computer and the stress analysis.
- ◆ All bearings are from famous brand. The bearings have high loading support and safety.
- ◆ The input and output are protected with radial shaft seals and V type seals. Viton material improves the seal life.
- ◆ High modular design. Volume production is more economic and speeds up the delivery period.
- ◆ 2 stage, 3 stage and 4 stage design and wide range of ratio.
- ◆ Low noise, high efficiency and long operation life.
- ◆ Easy mounting and maintenance.

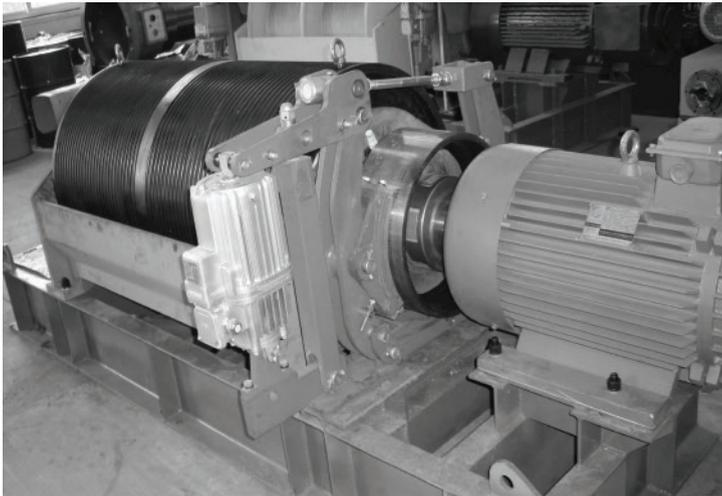

- 港口起重机
- 随车吊和汽车吊
- 建筑起重机和输送设备
- 货运和工作电梯
- 甲板起重机
- 集装箱龙门吊
- 汽车和履带式起重机
- 海上平台起重机
- Harbour cranes
- Mobile cranes
- Construction cranes and conveyors
- Material and working elevators
- Deck cranes
- Container gantries
- Crawling crane
- Offshore cranes

博能公司全系列产品采用独创的模块化设计，零部件通用最大化，具有量产优势，标准零配件成本低，供货周期短，整个产品系列均采用高制造标准，保证了极好的承载能力和工作可靠性。

All series products of Boneng use the original modular design, parts general maximization, it has advantage of mass production, the standard parts of low costs, short delivery cycle. The whole product series adopt high manufacturing standards to ensure the excellent carrying capacity and working reliability.

注意事项！必须严格遵守以下各项！

Note: You must conform to the following instructions

- ◆ 样本中的结构示意图、外形图及其他附图只属范例，无严格比例要求。(未注尺寸单位均为mm)。
- ◆ 所注重量仅为平均值，并不具有约束力。
- ◆ 为防止意外事故发生，所有旋转部件均按照使用者所在国家和地区的安全规范由购置方加罩保护。
- ◆ 试车之前必须认真阅读使用说明书。
- ◆ 齿轮箱在供货时已处于准运行状态，运行前需加注润滑油。
- ◆ 说明书中注油量只作为参考值，实际注油量应以油镜上的标记为准。
- ◆ 润滑油粘度应按齿轮箱使用工况及使用环境温度选取。
- ◆ 只能采用国际知名品牌的润滑油。

- ◆ All the construction figures, dimension drawings and other drawings in the catalogue are only the examples, no strict scale defined. (The unmarked dimension units are mm)
- ◆ The marked weight is only the average value, no binding.
- ◆ To avoid the accident, all the rotation components should be covered by customer according to the local safety regulations and laws.
- ◆ Read the instructions carefully before operating.
- ◆ Fill the lubrication oil before running.
- ◆ The oil quantity in the instructions is only for reference. The actual oil value should be done as the oil glass level.
- ◆ The adhesiveness of lubrication is depended on the operating condition and the ambient temperature.
- ◆ Only choose the international famous brand lubrication oil.

产品功能标识/The functional label of gearbox



油 镜 /Oil glass



通气帽 /Breather



进油孔 /Oil filler



放油孔 /Oil drain

目 录 Contents

▲-----	结构简图/Design and Construction	01
▲-----	型号表示/Type description	02
▲-----	输入方式/Input modes	02
▲-----	卷筒概述/Integrated Rope Drum	03
▲-----	阀块说明/Valve explanation	05
▲-----	选型说明/Type selection explanation	08
▲-----	传动能力/Transmission capacity	10
▲-----	外形尺寸/Outline dimension	11
▲-----	安装规则/Mounting method	13
▲-----	润滑说明/Lubrication	14
▲-----	附件/Accessories	14
▲-----	轴端中心孔/End shaft central hole	15
▲-----	平键与键槽尺寸/Key and Keyway size	16
▲-----	设计参数表/Parameter table	17

1 结构简图

1 Design and Construction

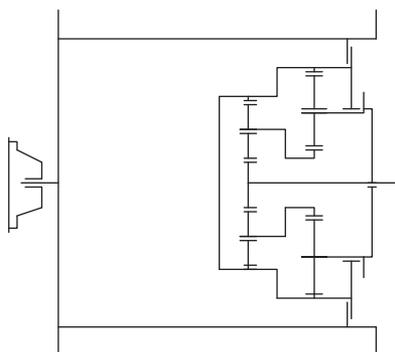

二级行星传动齿轮箱

额定输出扭矩: 11.6至155kN·m
 钢丝绳负载: 67至408KN
 公称减速比13至28
 齿轮箱内置于滚筒
 输入与输出旋转方向相反

2 stage planetary gearbox

Output torques: 11.6 to 155 KN.m
 Rope load: 67 to 408KN
 Ratio from $i=13$ to 28
 Gearbox mounted inside winch drum.
 Input and output in opposite sense of rotation

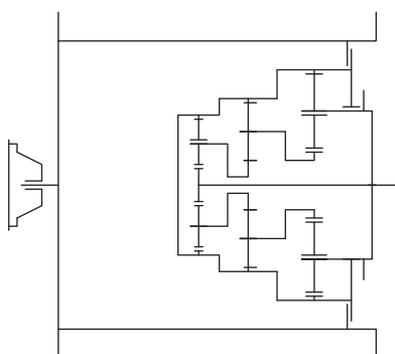

三级行星传动齿轮箱

额定输出扭矩: 25至236kN·m
 钢丝绳负载: 116至566KN
 公称减速比45至141
 齿轮箱内置于滚筒
 输入与输出旋转方向相反

3 stage planetary gearbox

Output torques: 25 to 236 KN.m
 Rope load: 116 to 566 KN
 Ratio from $i=45$ to 141
 Gearbox mounted inside winch drum.
 Input and output in opposite sense of rotation

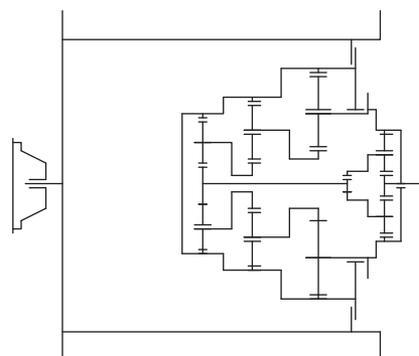

四级行星传动齿轮箱

额定输出扭矩: 47至1500kN·m
 钢丝绳负载: 180至1950KN
 公称减速比167至940
 齿轮箱内置于滚筒
 输入与输出旋转方向相反

4 stage planetary gearbox

Output torques: 47 to 1500 KN.m
 Rope load: 180 to 1950 KN
 Ratio from $i=167$ to 940
 Gearbox mounted inside winch drum.
 Input and output in opposite sense of rotation

备注: 各级传动的机械效率为98%，钢丝绳滚筒轴承及密封圈的机械效率为99%。

例如: 两级行星卷扬机的总机械效率为 $\eta = 0.98 \times 0.98 \times 0.99 = 0.95$

Remark: Mechanical efficiency of every stage is 98%, bearings for rope drum and the seal rings mechanical efficiency is 99%

For example: the total mechanical efficiency for 2 stage winch planetary gearbox $\eta = 0.98 \times 0.98 \times 0.99 = 0.95$

2 型号表示

2 Type description

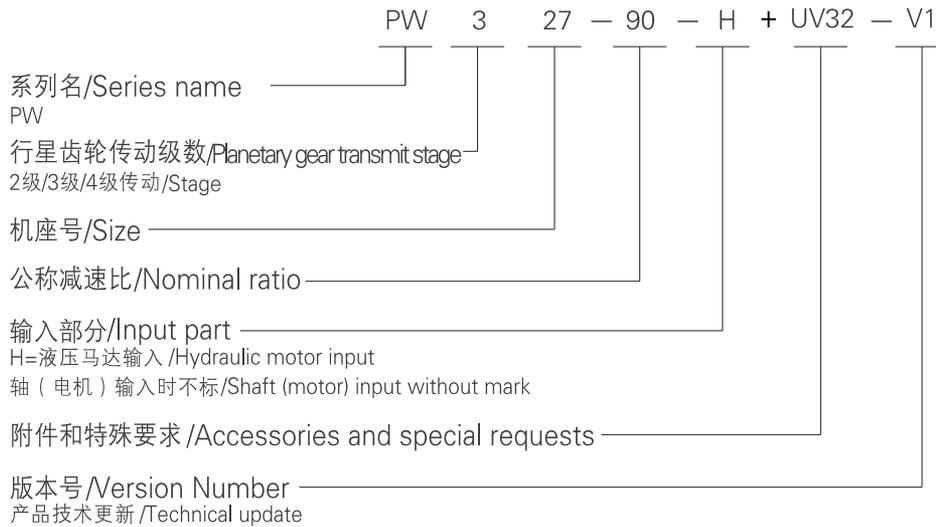

3 输入方式

3 Input modes

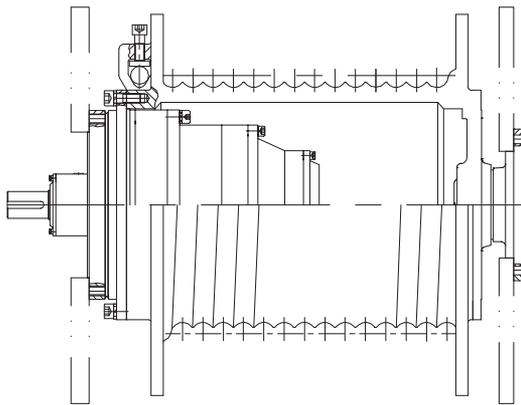

电机输入，水平安装 /Motor input foot mounted

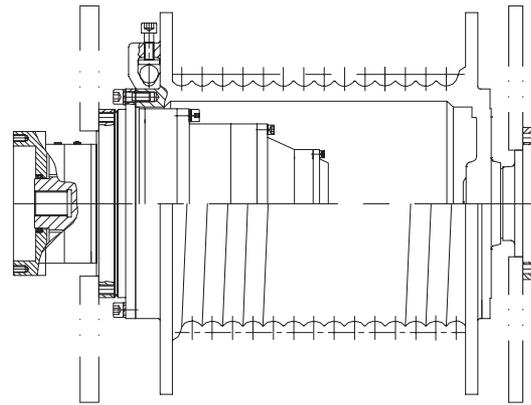

液压马达输入，水平安装 /Hydraulic motor input, foot mounted

产品配备电动机、液压马达两种模块化输入系统。
液压马达输入时，输入轴为DIN 5480规格的花键轴，带有压力释放弹簧装置的液压多片式驻车制动系统。该制动安全装置是独立的活塞或制动器，其释放压力最小为15bar，最大承压为300bar，系统残留压力小于0.5bar。

备注：PW全系列行星齿轮内藏式卷扬齿轮箱可适配各种马达，如高速马达（单个或2—3个驱动单元）、摆线马达、低速大扭矩马达，能满足客户不同的应用与需求，具体使用请垂询。

PW with electric motor input and hydraulic motor input.
When hydraulic motor is input, the input shaft is a DIN 5480 spline shaft, equipped with the hydraulic pressure release and loose-spring multi disc brake parking system. This brake safety device is a self contained piston or brake with a minimum release pressure of 15 bar, the maximum pressure is 300 bar. System residual pressure is less than 0.5 bar.

Remark: PW complete range can be equipped with kinds of motors, such as high speed motor (Single or 2 — 3 drive units), cycloidal motor, low speed with big torque motor etc, can meet customer' s different demands. For details, please consult Boneng.

4 卷筒概述

4.1 卷筒种类:

- 1) 标准沟槽卷筒 (图1) 和特殊沟槽卷筒 (图2)。
- 2) 沟槽方向分左旋和右旋, 默认为右旋 (图1)。
- 3) 特殊沟槽卷筒可避免多层缠绕时的乱绳现象, 因为每层钢丝绳的交叉点在滚筒截面的同一位置上, 并且确定了下一层钢丝绳的螺旋升角, 可缠绕八层或更多层。



图1/Figure 1

4 Integrated Rope Drum

4.1 Drum categories:

- 1) Drum with normal grooves (figure 1) and with special grooves (figure 2).
- 2) Rope groove has right hand lead and left hand. The default lead is right hand (figure 1).
- 3) Drum with special grooves can avoid the difficulties encountered in multi-layer winding on to grooves of the usual kind. As the crossover points of the rope in each layer always lie in the same section of the drum and the spiral angle of the next layer rope is determined, 8 and more layers can be accommodated without difficulty.

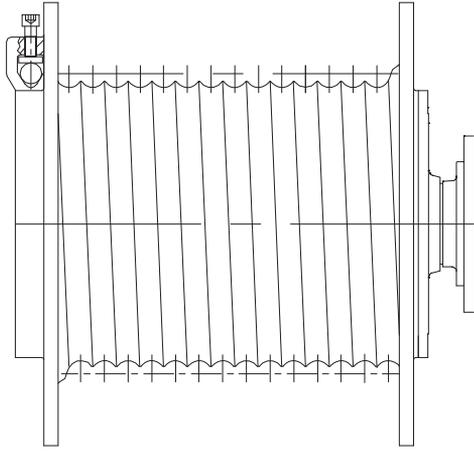

图2/ Figure 2

4.2 钢丝绳固定方式: 在滚筒侧壁外侧

4.2 Rope fixing: on the outside of the drum flange

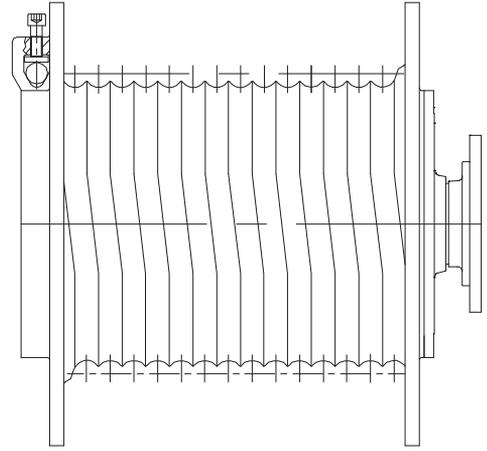

图3/Figure 3

4.3 为了保证钢丝绳正常缠绕，要求绳偏折角 α 维持在允许范围之内（图4），应注意以下几点：

- 1) 钢丝绳的捻转方向应与卷筒沟槽方向相反。
- 2) 绳偏折角 α 不应小于 0.5° ，以防钢丝绳在侧壁处堆积，保证钢丝绳分层缠绕。
- 3) 绳偏折角 α 不应大于 1.5° ，为了使钢丝绳在第一层不受与绳槽方向相反的拉力，保证多层缠绕时钢丝绳在滚筒挡板之间均匀的分布。

4.3 To achieve acceptable rope winding, the deflection angle α must be kept in the allowable value (figure 4) Attend the following points:

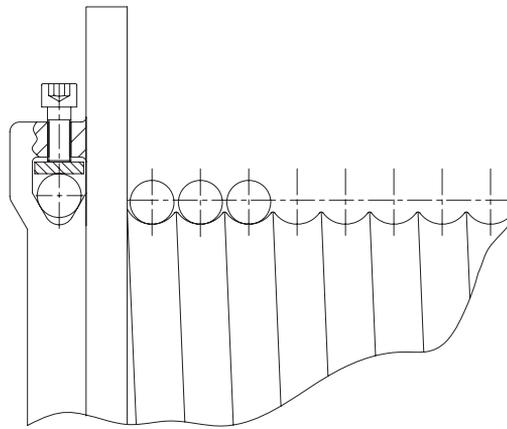
- 1) Rope lay should be in the opposite sense to drum lead.
- 2) The deflection angle α must not less than 0.5° in order to prevent the rope from riding up the drum flange and to ensure that it is guided securely on to the next layer.
- 3) The deflection angle α must not exceed 1.5° in order to prevent the rope in the first layer being pulled against the grooves and, where a number of layers occur, to enable even winding up to the drum flanges.



图4/ Figure 4

4.4 卷筒和钢丝绳相关计算（图5）：

卷筒直径 $D1=20xd$ 或按客户要求

卷筒法兰直径： $D2=D1+2(Z+1)d$

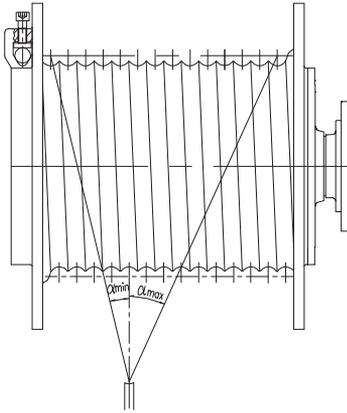
钢丝绳绳长（包含三圈过放保险钢丝绳）：

4.4 The related calculations between drum and rope (figure 5):

Rope drum diameter $D1= 20 \times d$ or as specified

Drum flange diameter $D2= D1 + 2 (Z + 1) d$

Length of rope (including 3 safety turns)

$$L_s = \left(\frac{L_2}{p} - a \right) (D1 + 0.866 * d * (z-1)) \frac{z * \pi}{1000}$$

L_s ：钢丝绳绳长（m）

L_2 ：卷筒长度或两挡板间距（mm）

$D1$ ：卷筒直径（mm）

d ：钢丝绳直径（mm）

p ：绳槽螺旋升角或节距（mm）

Z ：钢丝绳缠绕层数

a ：标准沟槽卷筒 $a=1$ ；特殊沟槽卷筒 $a=0.5$

LS = Length of rope [m]

L_2 = Length of drum [mm]

$D1$ = Diameter of drum [mm]

d = Diameter of rope [mm]

p = Pitch of rope groove [mm]

z = Number of rope layers

$a = 1$ for normal grooves , $a = 0,5$ for special grooves



图5/ Figure 5

5 阀块说明

根据卷扬的不同使用工况，需要在驱动马达上配备一些辅助阀块来保证卷扬安全、正常的工作。

卷扬驱动马达用阀块分为两种：一种是用于开式液压系统的马达集成阀块：该阀块将负载平衡、缓冲压力冲击、制动器自动开启等功能集成在一起；一种是用于闭式液压系统的管路防爆安全阀：该阀块主要可在管路爆裂时锁住马达，防止马达失速。

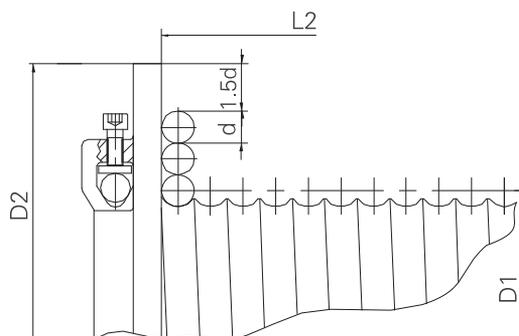
5.1 开式系统马达用阀块

马达集成阀块作为卷扬驱动马达用标准阀块，优先推荐客户使用此阀块。如果客户只使用该阀块中的一种功能，则需要非标设计。

5.1.1 马达集成阀块

卷扬驱动马达用集成阀块具有缓冲压力冲击、平衡负载、刹车制动打开等功能，阀块原理图：平衡阀位于马达B侧油口（图6）、平衡阀位于马达A侧油口（图7）。

当马达A口进油时卷扬进行放绳则选择图6所示阀块；当马达B口进油时卷扬进行放绳则选择图7所示阀块。



图6 马达集成阀块
Figure 6 motor integrated valve

5 Valve explanation

According to different working condition, the drive motor should be equipped with the valve to make sure the hoisting winch running safely.

There are two different valves: One is the motor integrated valve with open hydraulic system. The valve can control the load while it is descending, lighten the pressure and opening the brake automatically. Another is the tube explosion-proof valve with close hydraulic system. The valve can lock the motor when the tube is exploded and prevent the fail save motor.

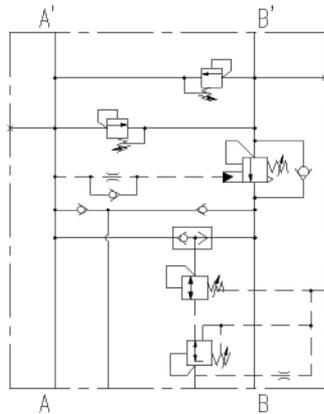
5.1 The motor integrated valve with open hydraulic system

The motor integrated valve is the standard valve for the hoisting winch drive, we suggest the customer to use the valve in advance. If customer need only use one of the valve function, it should be customized.

5.1.1 Motor integrated valve

The motor integrated valve can lighten the pressure, control the load and open the integrated motor brake automatically. Valve working principle drawing: the balance valve is on the oil port B side of motor (figure 6), the balance valve is on the oil port A side of motor (figure 7).

When filling the oil on motor A side and pull the rope, should select the valve as figure 6; When filling the oil on motor B side and pull the rope, should select the valve as figure 7.



图7 马达集成阀块
Figure 7 motor integrated valve

阀块功能说明：

- 1) 卷扬在吊装作业时承受负值负载，为保证卷扬在承受负值负载时依然能平稳运行，不出现失速，需要在马达上安装平衡阀。
- 2) 卷扬在使用时，随着钢丝绳拉力的变化，负载不平稳容易导致液压系统压力波动，并出现较高的压力峰值，为了防止压力过高损坏液压马达，需要应用缓冲阀释放压力峰值。
- 3) 卷扬停止工作时为保证卷扬可靠锁至，不出现溜钩现象，需要在卷扬上安装制动器。马达集成阀块中的刹车开启功能可实现制动器在卷扬工作时自动打开、停止工作时自动关闭。

备注：阀块中平衡阀的安装方位至关重要，至于如何确定马达A侧、还是B侧安装平衡阀，可参考：滚筒旋转方向说明。

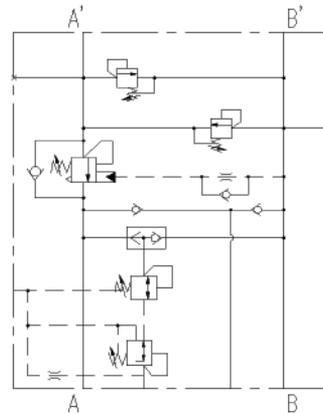
Valve function:

- 1) When the hoisting winch is operating under negative loading, we should mount the balance valve on the motor to prevent the hoisting winch from stalled glide and keep the stable operating.
- 2) When the rope pulling force is changing and the load is unstable, it will cause the hydraulic pressure wave and there is the higher pressure, we should mount the cushion valve to release the pressure to prevent the hydraulic system damaged.
- 3) Brake is mounted to prevent the hoisting winch from slipping when the hoisting winch stops running and is locked well. The brake in the motor integrated valve can open automatically when the hoisting winch is operating and will close automatically when the hoisting winch is stopping.

Remark: the balance valve mounting position is very important. How to confirm the mounting position is on the A side or B side of motor, you can refer to the winding direction on the rope drums.

5.2 闭式系统马达用阀块

闭式系统可通过液压泵实现静液压制动，由发动机吸收制动扭矩，一般不推荐使用平衡阀，以防止系统液压油温度过高，如果客户有特殊需要，需进行技术论证。

5.2 The motor integrated valve with close hydraulic system

The close hydraulic system can achieve the hydrostatic brake through the hydraulic pump, and motor can absorb the brake torque, usually balance valve is not suggested to keep from the hydraulic oil temperature too high. If customer has this special demand, the technical testing should be done.

5.2.1 管路防爆安全阀块

为了保证客户安全的使用卷扬设备，推荐客户使用管路防爆安全阀。该阀块可在液压管路发生爆裂时，切断马达回油口，依靠马达回油口背压对马达进行动态制动，防止卷扬失速，重物下坠。

5.2.1 The tube explosion-proof valve

To ensure the correct using hoisting winch, we suggest customer to use the tube explosion-proof valve. It can cut off the returned oil port of motor when the hydraulic tube is split. The counter pressure of the returned oil port will make the dynamic brake on the motor to prevent the hoisting winch from slipping.

管路防爆安全阀块原理图：防爆安全阀位于马达A侧油口（图8）、防爆安全阀位于马达B侧油口（图9）。

The tube explosion-proof valve working principle drawing: the tube explosion-proof valve is on the oil port A side of motor (figure 8), the tube explosion-proof valve is on the oil port B side of motor (figure 9).



图8 管路防爆安全阀

Figure 8 The tube explosion-proof valve

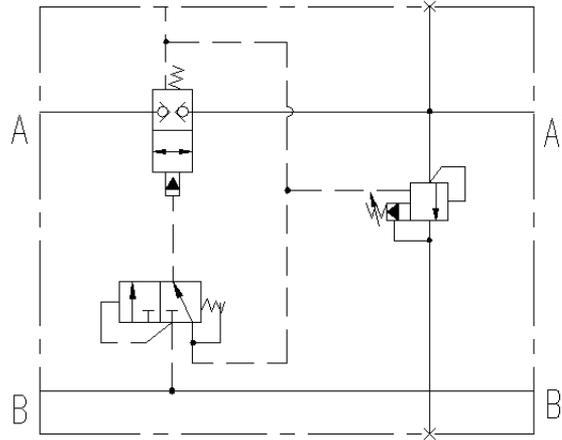

图9 管路防爆安全阀

Figure 9 The tube explosion-proof valve

当马达B口进油时卷扬进行放绳则选择图8所示阀块；
当马达A口进油时卷扬进行放绳则选择图9所示阀块。

When filling the oil on motor B side and pull the rope, should select the valve as figure 8;
When filling the oil on motor A side and pull the rope, should select the valve as figure 9.

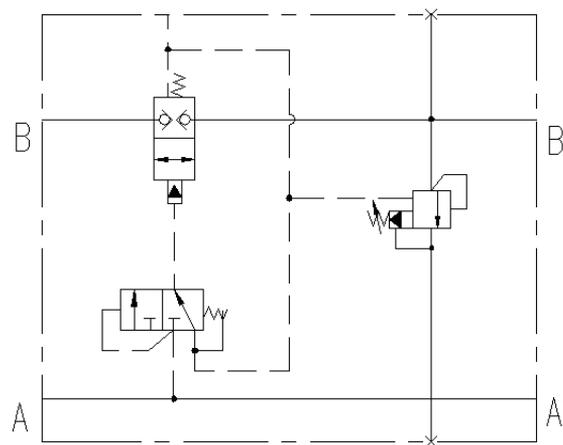
备注： 防爆安全阀的安装方位至关重要，至于如何确定马达A侧、还是B侧安装防爆安全，可参考：滚筒旋转方向说明。

Remark: the tube explosion-proof valve mounting position is very important. How to confirm the mounting position is on the A side or B side of motor, you can refer to the winding direction on the rope drums.

5.3 滚筒旋转方向说明

5.3 Winding direction on the rope drums.

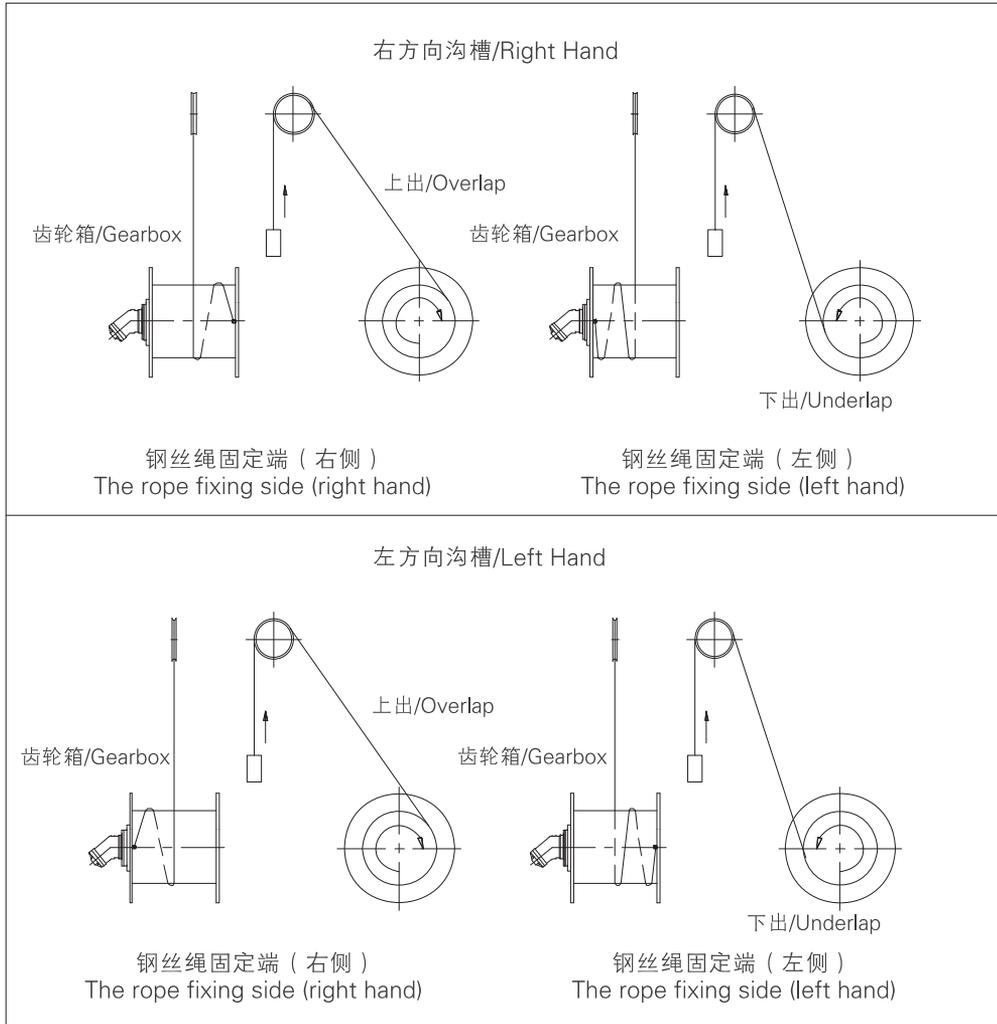

钢丝绳方向 Rope direction	绳槽旋向 Rope groove lead	出绳方式 Rope pull mode	齿轮箱输出 Gearbox output	齿轮箱输入 Gearbox input	马达旋向 Motor rotation	马达进油口 Motor inlet oil port	平衡阀/防爆安全阀安装侧 Balance valve/ explosion-proof valve mounting position
提绳/Draw rope	右方向/Right hand	上出绳/overshot	顺时针/CW	逆时针/CCW	顺时针/CW	A (B)	A (B)
	右方向/Right hand	下出绳/undershot	逆时针/CCW	顺时针/CW	逆时针/CCW	B (A)	B (A)
	左方向/Left hand	上出绳/undershot	顺时针/CW	逆时针/CCW	顺时针/CW	A (B)	A (B)
	左方向/Left hand	下出绳/undershot	逆时针/CCW	顺时针/CW	逆时针/CCW	B (A)	B (A)
放绳/Release rope	右方向/Right hand	上出绳/overshot	逆时针/CCW	顺时针/CW	逆时针/CCW	B (A)	A (B)
	右方向/Right hand	下出绳/undershot	顺时针/CW	逆时针/CCW	顺时针/CW	A (B)	B (A)
	左方向/Left hand	上出绳/overshot	逆时针/CCW	顺时针/CW	逆时针/CCW	B (A)	A (B)
	左方向/Left hand	下出绳/undershot	顺时针/CW	逆时针/CCW	顺时针/CW	A (B)	B (A)

备注: 1) 表中齿轮箱的输入输出方向定义为: 正对齿轮箱输入侧看。
 2) 表中液压马达旋转方向定义为: 正对马达输出轴看。
 3) 滚筒方向定义为: 正对马达齿轮箱输入侧看, 滚筒方向即齿轮箱输出方向。

Remark: 1) Gearbox output and input direction in above table: when facing the gearbox input shaft.
 2) The motor rotation in above table: when facing the motor output shaft.
 3) The drum rotation: When facing the gearbox input shaft, the gearbox output shaft rotation is the drum rotation.

6 选型说明

6.1 使用说明

PW行星齿轮箱额定动态输出扭矩 $T_{dyn\ max}$ 按欧洲起重机械联合会标准FEM (FEM—Federation Europeenne de la Manutention) 第三版第一章, 驱动机构等级M5, 负载分组L2 (P=常数, =15rpm), 工况等级T5分组设计。工作环境温度+20°C。

如果卷扬机构分级为其它工作级别, 则其所需输出扭矩必须采用系数K进行修正。

T_2 : 输出扭矩/output torque (N · m)

F_{nom} : 单绳拉力/single rope pull (N)

D_w : 相应卷绕直径/rope strands diameter (m)

$$T_2 = \frac{F_{nom} * D_w}{2}$$

T_{2k} : 修正后的输出扭矩/output torque with multiplied factor (N · m)

K: 工况系数 (设备分组工况系数) /application factor (the relative factor for drive unit group and load conditions)

$$T_{2k} = T_2 * K$$

注: 齿轮箱选型时 T_{2k} 必须 $\leq T_{dyn\ max}$ (设计扭矩或样本扭矩) Note: $T_{2k} \leq T_{dyn\ max}$ (design torque or sample torque)

6 Type selection explanation

6.1 Operation instruction

PW rated dynamic output torques $T_{dyn\ max}$ are based on FEM Standards section 1, 3rd edition (FEM – Federation Europeenne de la Manutention). Drive unit group M5, load conditions L2 (P=constant, =15rpm), running time classification T5. Ambient temperature +20 °C.

If the hoisting winch is classified as other working grades, the output torque must be multiplied by the factor K.

6.2 工况系数 (机构利用等级和载荷状态分级)

6.2 Application factor K (running time classification and load conditions)

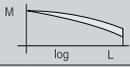
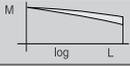
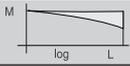
工况等级 Running time classification	运行时间级别/Symbol	T2	T3	T4	T5	T6	T7	T8
	一年内, 日平均工作时间 (小时) Mean running time per day in hours, related to one year		0.25至/to0.5	0.5至/to1	1至/to2	2至/to4	4至/to8	8至/to16
使用寿命 (小时) 8年, 200天/年 Life in hours 8 years, 200 days/year		400至/to800	800至/to1600	1600至/to3200	3200至/to6300	6300至/to12500	12500至/to25000	25000至/to50000
负载情况 Load conditions	集合系数/Collective coefficient Km	设备分组工况系数/Drive unit class Application Factor K						
L1	 至/to0.125	M1 0.90	M2 0.90	M3 0.90	M4 0.92	M5 0.92	M6 1.1	M7 1.36
L2	 0.125至/to0.250	M2 0.90	M3 0.92	M4 0.96	M5 1	M6 1.07	M7 1.3	M8 1.6
L3	 0.250至/to0.500	M3 1.05	M4 1.09	M5 1.17	M6 1.23	M7 1.28	M8 1.53	M8 1.89
L4	 0.500至/to1.000	M4 1.32	M5 1.36	M6 1.46	M7 1.53	M8 1.58	M8 1.8	M8 2.22

6.3 起重机械典型载荷谱 (图10)

6.3 Typical load spectrum for crane (figure 10)



图10起重机械典型载荷谱
Figure 10 Crane load spectrum

6.4设备分级指导 参见FEM标准第三版第一章,表T.2.1.3.5

6.4Classification Guidance According FEM section 1, 3rd edition, table T.2.1.3.5

起重机类型/ Type of Crane (name)	工作元件 Working accessories	驱动机构类型/ Type of mechanism				
		起升 Hoisting	回转 Slewing	变幅 Luffing	小车运行 Traverse	大车运行 Travel
安装用起重机/Erection cranes		M2-M3	M2-M3	M1-M2	M1-M2	M2-M3
桥式起重机/Bridge crane	吊钩/Hook duty	M5-M6	M4	-	M4-M5	M5-M6
桥式起重机/Bridge crane	抓斗或磁铁 Grab or magnet	M7-M8	M6	-	M6-M7	M7-M8
车间用起重机/Workshop cranes	抓斗或磁铁 Grab or magnet	M6	M4	-	M4	M5
天车, 旁锤起重机. 废钢场起重机 Crane, Ram crane, Scrap mill crane	吊钩或磁铁 Hook or magnet	M8	M6	-	M6-M7	M7-M8
卸料桥, 集装箱用门式起重机 Unloading bridge, Container gantry crane	吊钩/Hook	M6-M7	M5-M6	M3-M4	M6-M7	M4-M5
其它门式起重机(带小车和/或转台) Other gantry crane(with crab and/or slewing jib crane)	抓斗或磁铁 Grab or magnet	M4-M5	M4-M5	-	M4-M5	M4-M5
卸料桥, 集装箱用门式起重机 (带小车或转台) Unloading bridge, Container gantry crane(with crab and/or slewing jib crane)	吊钩/Hook	M8	M5-M6	M3-M4	M7-M8	M4-M5
船台起重机船坞起重机, 拆卸用起重机 Shipyards crane, Dock crane, Disassembly crane		M5-M6	M4-M5	M4-M5	M4-M5	M5-M6
港口起重机(可转动, 门式), 浮式起重机, 浮式起重架 Dockside cranes (slewing, on gantry, etc.), floating cranes and pontoon derricks	吊钩/Hook	M6-M7	M5-M6	M5-M6	-	M3-M4
港口起重机(可转动, 门式), 浮式起重机, 浮式起重架 Dockside cranes (slewing, on gantry, etc.), floating cranes and pontoon derricks	抓斗或磁铁 Grab or magnet	M7-M8	M6-M7	M6-M7	-	M4-M5
浮式起重机和浮式起重架, 用于非常高的负荷 (一般在100t以上) Floating cranes and pontoon derricks for very heavy loads (usually greater than 100 t)		M3-M4	M3-M4	M3-M4	-	-
甲板起重机/Deck cranes	吊钩/Hook	M4	M3-M4	M3-M4	M2	M3
甲板起重机/Deck cranes	抓斗或磁铁 Grab or magnet	M5-M6	M3-M4	M3-M4	M4-M5	M3-M4
塔式起重机用于建筑工地 Tower cranes for building		M4	M5	M4	M3	M3
门式塔架/ Derricks		M2-M3	M1-M2	M1-M2	-	-
铁路起重机, 批准用于铁路维修 Railway cranes allowed to run in train		M3-M4	M2-M3	M2-M3	-	-
车辆起重机/Mobile cranes	吊钩/Hook	M3-M4	M3-M4	M2-M3	-	-

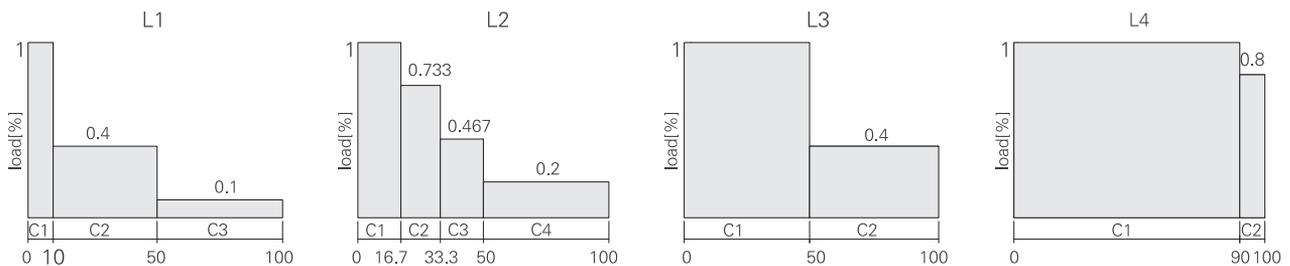
备注: 仅列出了卷扬机构的一些典型范围以供参考

Note: Above are only some typical applications for hoisting winch.

7 传动能力

7 Transmission capacity

公称减速比 Nominal ratio	精确减速比 Exact ratio	型号/typePW	20	22	24	25	26	27	29	31	32	33	34	36	38	40
i_N	i_{ex}	T动/dynamic kN·m	11.6	19.4	25.5	36	48	63	105	155	236	311	406	644	1100	1500
		T静/static kN·m	18.5	31	41	57.5	77	101	168	248	377.5	497.5	649.5	1030.5	1760	2400
13	13.11	2级/stage	☆	☆	☆	☆	☆	☆	☆	☆	☆					
15	15.14		☆	☆	☆	☆	☆	☆	☆	☆	☆					
18	18.22		☆	☆	☆	☆	☆	☆	☆	☆	☆					
20	20.45		☆	☆	☆	☆	☆	☆	☆	☆	☆					
23	23.47		☆	☆	☆	☆	☆	☆	☆	☆	☆					
28	27.79		☆	☆	☆	☆	☆	☆	☆	☆	☆					
45	44.97	3级/stage	☆	☆	☆	☆	☆	☆	☆	☆	☆					
52	51.56		☆	☆	☆	☆	☆	☆	☆	☆	☆					
59	59.10		☆	☆	☆	☆	☆	☆	☆	☆	☆					
71	70.57		☆	☆	☆	☆	☆	☆	☆	☆	☆					
79	78.88		☆	☆	☆	☆	☆	☆	☆	☆	☆					
84	84.23		☆	☆	☆	☆	☆	☆	☆	☆	☆					
90	90.13		☆	☆	☆	☆	☆	☆	☆	☆	☆					
105	105.18		☆	☆	☆	☆	☆	☆	☆	☆	☆					
120	120.13		☆	☆	☆	☆	☆	☆	☆	☆	☆					
141	141.49		☆	☆	☆	☆	☆	☆	☆	☆	☆					
167	167.48		☆	☆	☆	☆	☆	☆	☆							
192	192.03	☆	☆	☆	☆	☆	☆	☆	☆	☆	☆	☆	☆			
220	220.1	☆	☆	☆	☆	☆	☆	☆	☆	☆	☆	☆	☆	☆	☆	
262	262.1	☆	☆	☆	☆	☆	☆	☆	☆	☆	☆	☆	☆	☆	☆	
273	273.16	☆	☆	☆	☆	☆	☆	☆	☆	☆	☆	☆	☆	☆	☆	
293	292.54	☆	☆	☆	☆	☆	☆	☆	☆	☆	☆	☆	☆	☆	☆	
313	312.95	☆	☆	☆	☆	☆	☆	☆	☆	☆	☆	☆	☆	☆	☆	
334	333.74	☆	☆	☆	☆	☆	☆	☆	☆	☆	☆	☆	☆	☆	☆	
349	349.31	☆	☆	☆	☆	☆	☆	☆	☆	☆	☆	☆	☆	☆	☆	
374	373.52	☆	☆	☆	☆	☆	☆	☆	☆	☆	☆	☆	☆	☆	☆	
393	392.59	☆	☆	☆	☆	☆	☆	☆	☆	☆	☆	☆	☆	☆	☆	
417	416.91	☆	☆	☆	☆	☆	☆	☆	☆	☆	☆	☆	☆	☆	☆	
445	445.46	4级/stage	☆	☆	☆	☆	☆	☆	☆	☆	☆	☆	☆	☆	☆	☆
476	475.62		☆	☆	☆	☆	☆	☆	☆	☆	☆	☆	☆	☆	☆	☆
509	508.98		☆	☆	☆	☆	☆	☆	☆	☆	☆	☆	☆	☆	☆	☆
532	531.54		☆	☆	☆	☆	☆	☆	☆	☆	☆	☆	☆	☆	☆	☆
559	559.49		☆	☆	☆	☆	☆	☆	☆	☆	☆	☆	☆	☆	☆	☆
594	593.94		☆	☆	☆	☆	☆	☆	☆	☆	☆	☆	☆	☆	☆	☆
625	625.27		☆	☆	☆	☆	☆	☆	☆	☆	☆	☆	☆	☆	☆	☆
678	678.38		☆	☆	☆	☆	☆	☆	☆	☆	☆	☆	☆	☆	☆	☆
699	698.68		☆	☆	☆	☆	☆	☆	☆	☆	☆	☆	☆	☆	☆	☆
798	798		☆	☆	☆	☆	☆	☆	☆	☆	☆	☆	☆	☆	☆	☆
841	841.37		☆	☆	☆	☆	☆	☆	☆	☆	☆	☆	☆	☆	☆	☆
940	939.89		☆	☆	☆	☆	☆	☆	☆	☆	☆	☆	☆	☆	☆	☆

备注：未注减速比请垂询！

Note: For ratios not listed, please contact!

8 外形尺寸

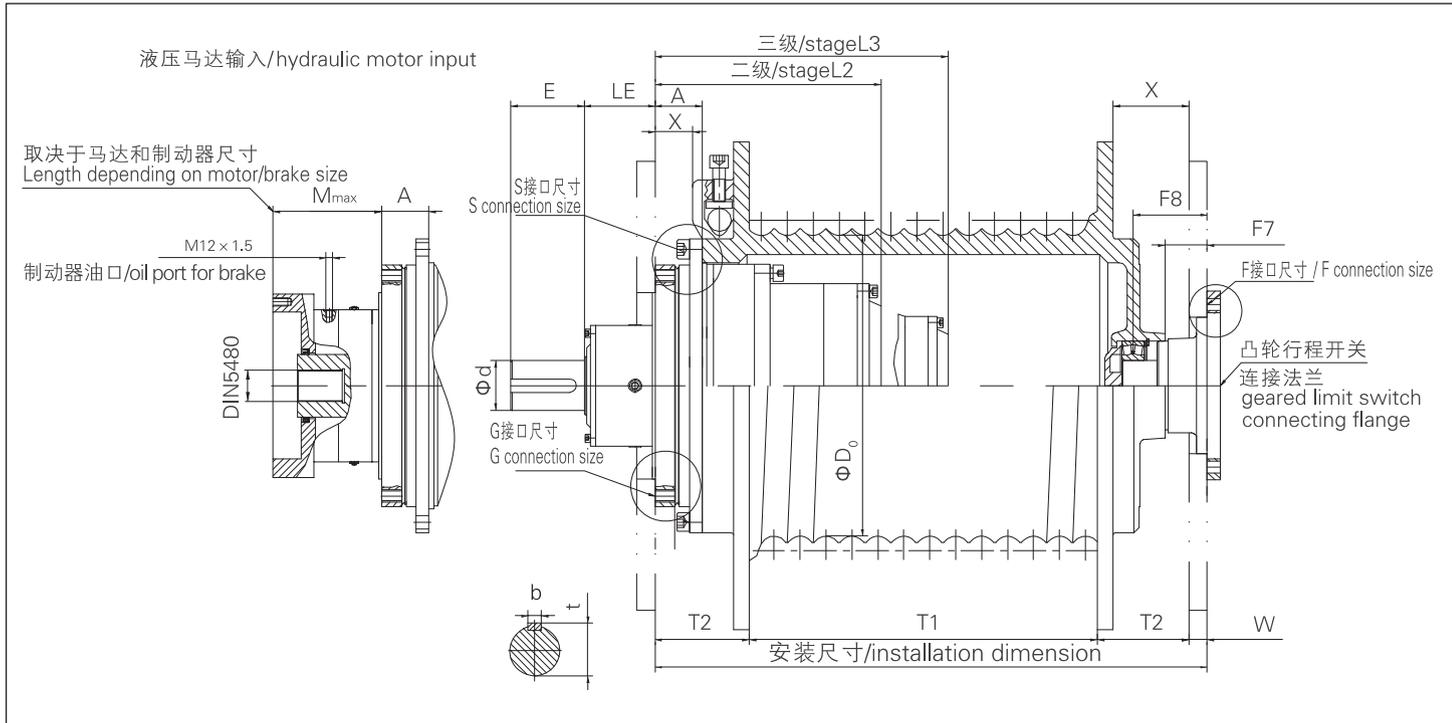

型号 Type	公称数据输出扭矩 Nominal Gearbox ratings Output torque (KNm)			G接口尺寸/G Flange connection 齿轮箱与钢结构连接螺栓强度等级10.9 10.9 Gearbox to frame bolts class 10.9						S接口尺寸/S Flange connection 齿轮箱与滚筒连接螺栓强度等级8.8 8.8 Gearbox to drum bolts class 8.8						F接口尺寸/F Flange connection 滚筒法兰与钢结构连接螺栓强度等级8.8 8.8 Drum flange to frame bolts class 8.8							
	单绳 最大 拉力 T _{dyn} max	单绳 最大 拉力 T _{static} max	单绳 最大 拉力 F _{nom} KN	G1 止口 Location	G2 分度圆 Pitch diameter	G3 外径 outer diameter	G4 分度 fixing	G5	G6	S1 止口 Location	S2 分度圆 Pitch diameter	S3 外径 outer diameter	S4 分度 fixing	S5	S6	F1 止口 Location	F2 分度圆 Pitch diameter	F3 外径 outer diameter	F4 分度 fixing	F5	F6	F7	F8
20	11.6	18.5	69	200h7	255 ± 0.2	285	20° 16*M16	25	5	295h7	320 ± 0.2	340	15° 24*φ14	12	9	175h7	200 ± 0.2	225	60° 6*φ11	15	10	30	64
22	19.4	31	98	230h7	280 ± 0.2	315	15° 22*M16	25	5	330h7	360 ± 0.2	390	20° 18*φ18	16	9	200h7	230 ± 0.2	260	60° 6*φ14	18	12	35	71
24	25.5	41	119	270h7	320 ± 0.2	355	15° 22*M16	25	5	370h7	400 ± 0.2	430	15° 24*φ18	16	9	200h7	230 ± 0.2	260	60° 6*φ14	18	12	35	71
25	36	57.5	147	300h7	350 ± 0.2	385	15° 22*M20	30	5	400h7	440 ± 0.2	480	20° 18*φ22	20	9	230h7	260 ± 0.2	290	60° 6*φ18	18	15	40	78
26	48	77	184	330h7	390 ± 0.2	425	15° 22*M20	30	5	440h7	480 ± 0.2	520	15° 24*φ22	20	9	260h7	310 ± 0.2	360	60° 6*φ22	25	15	50	92
27	63	101	220	355h7	420 ± 0.2	460	15° 22*M24	38	5	470h7	520 ± 0.2	560	20° 18*φ26	24	9	260h7	310 ± 0.2	360	60° 6*φ22	25	15	50	92
29	105	168	313	430h7	480 ± 0.2	530	15° 22*M24	38	5	550h7	590 ± 0.2	630	15° 24*φ26	24	9	300h7	350 ± 0.2	400	60° 6*φ22	30	15	50	104
31	155	248	408	515h7	565 ± 0.2	615	15° 24*M30	47	5	640h7	690 ± 0.2	750	15° 24*φ33	30	9	325h7	375 ± 0.2	425	60° 6*φ26	35	15	70	134
32	236	377.5	566	580h7	630 ± 0.2	680	15° 24*M30	47	5	700h7	755 ± 0.2	815	15° 24*φ33	30	9	325h7	375 ± 0.2	425	60° 6*φ26	35	15	70	134
33	311	497.5	660	670h7	720 ± 0.2	770	12° 30*M30	47	5	790h7	840 ± 0.2	890	12° 30*φ33	30	9	375h7	435 ± 0.2	500	60° 6*φ33	40	15	80	144
34	406	649.5	787	720h7	770 ± 0.2	820	10° 36*M30	47	5	850h7	900 ± 0.2	950	10° 36*φ33	30	9	375h7	435 ± 0.2	500	60° 6*φ33	40	15	80	144
36	644	1030.5	1073	840h7	900 ± 0.2	960	10° 36*M36	56	5	1000h7	1055 ± 0.2	1120	10° 36*φ39	36	9	430h7	490 ± 0.2	550	60° 6*φ33	40	15	90	180
38	1100	1760	1520	1060h7	1140 ± 0.2	1210	10° 36*M30	78	26	1240h7	1320 ± 0.2	1390	10° 36*φ33	45	13	600h7	680 ± 0.2	750	30° 12*φ33	50	20	80	180
40	1500	2400	1950	1160h7	1240 ± 0.2	1310	10° 36*M30	78	26	1340h7	1420 ± 0.2	1490	10° 36*φ33	45	13	600h7	680 ± 0.2	750	30° 12*φ33	50	20	80	180

备注: 未注尺寸请垂询

8 Dimension Drawing

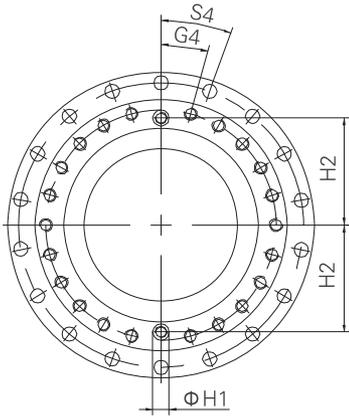

G接口尺寸/G Flange connection

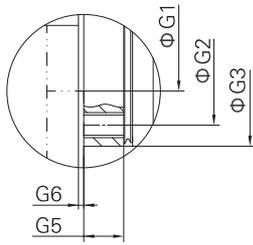

S接口尺寸/S Flange connection

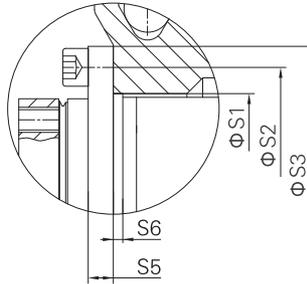

F接口尺寸/F Flange connection

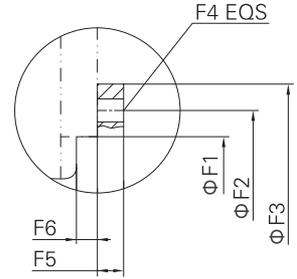

安装尺寸/installation dimension

轴(电机)输入/shaft (motor) input										油管接口 oil pump connection										重量/weight (Kg)		型号 Type		
2级/stage			3级/stage			4级/stage			液压 马达 输入 hydraulic motor input Mmax	A	L		T1min		D ₀	X	T2	W 推荐 suggestion	H1	H2	2级/stage	3级/stage	4级/stage	PW
d	E	LE	d	E	LE	d	E	LE		2级/stage L2	3级/stage L3	2级/stage	3级/stage	近似/Aprox min	min									
55m6	110	98.5	—	—	—	—	—	—	183	60	300	—	240	—	340	15	95	15	26	117	120	—	—	20
55m6	110	85	—	—	—	—	—	—	171	60	315	—	255	—	390	15	100	15	26	132	140	—	—	22
75m6	140	135.5	65m6	140	117.5	—	—	—	207	60	350	489	290	430	440	20	100	20	26	152	210	245	—	24
75m6	140	118	65m6	140	100	—	—	—	189	75	366	506	295	435	480	20	120	20	30	168	245	275	—	25
95m6	170	139.5	65m6	140	104.5	65m6	140	238	209	75	426	555	355	480	520	20	120	20	30	184	365	385	415	26
95m6	170	135	65m6	140	100	65m6	140	233.5	204	90	431	560	345	475	570	20	140	20	30	195.5	400	415	445	27
110m6	210	165	95m6	170	165	75m6	140	281	209	90	507	685	420	595	670	25	145	25	30	233	630	720	730	29
110m6	210	142	95m6	170	142	75m6	140	258	186	110	530	708	425	600	770	30	180	30	38	235	805	890	920	31
—	—	—	110m6	210	130	75m6	140	251	321	110	—	800	—	695	830	30	180	30	38	268	—	1320	1360	32
—	—	—	—	—	—	110m6	210	381	462	110	—	928	—	820	930	40	180	40	38	298	—	—	1970	33
—	—	—	—	—	—	110m6	210	377.5	458	120	—	932	—	815	1030	40	200	40	38	335	—	—	2195	34
—	—	—	—	—	—	110m6	210	264	345	120	—	1045	—	970	1200	50	240	50	38	385	—	—	2920	36
—	—	—	—	—	—	160m6	300	421	457	130	—	1415	—	1320	1360	50	240	60	45	497	—	—	6650	38
—	—	—	—	—	—	160m6	300	392	307	130	—	1444	—	1650	1530	50	240	60	45	545	—	—	7660	40

Note: For dimensions not listed, please contact!

9 安装规则

为了保证卷扬机的正常运转，卷扬齿轮箱与支撑钢结构 的安装孔必须对中，并且法兰安装面必须与其垂直。 钢结构安装孔与法兰安装面之间的相对位置在工作中、 环境影响及外力作用下不允许有过大的改变。卷扬机支 撑钢结构的制造公差及允许的最大变形见下表。

9 Assemble method

To ensure correct operation of the winch, the winch gearbox must be in the same line with the frame fixing hole centers and the flange pieces square to the base plate. The relative location between frame mounting central hole and flange mounting surface shouldn't be changed more when they are operating in different environment and outer force. The working tolerance and allowed max. deflections for the support frame are given in the accompanying table.

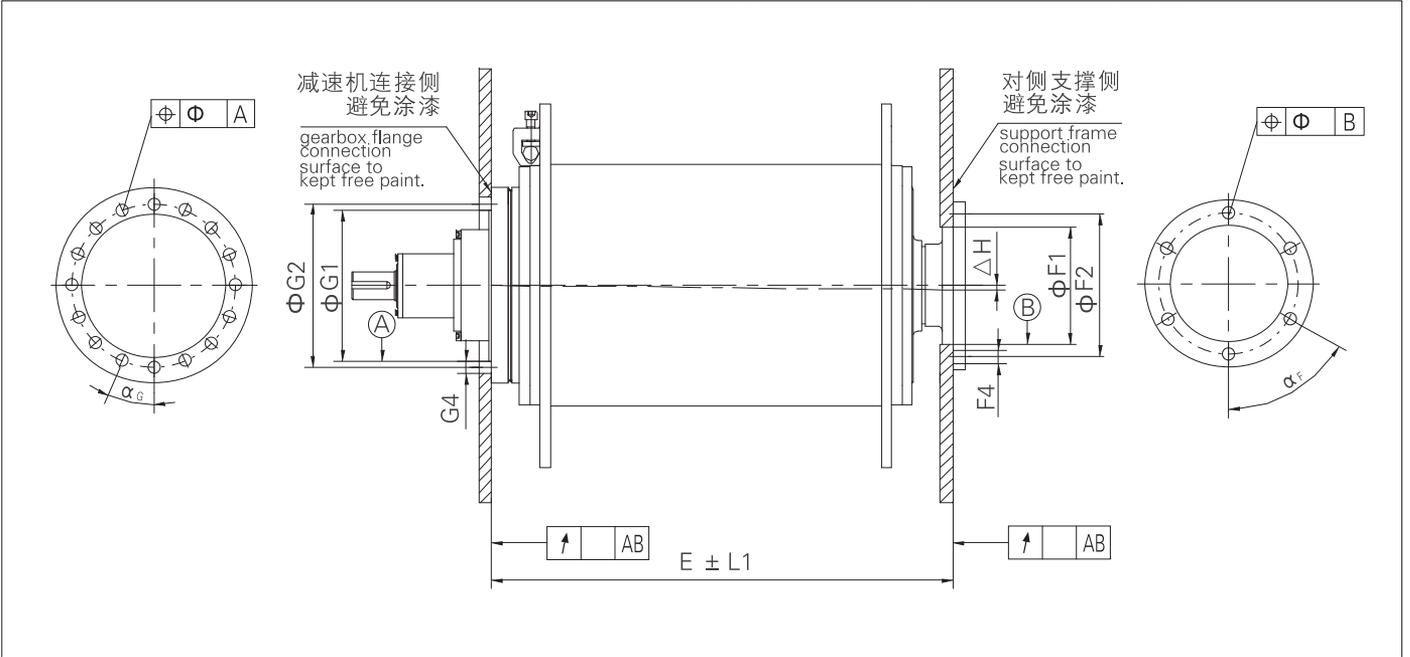

型号 Type	齿轮箱连接侧 gearbox flange connection			对侧支撑侧 support frame connection			组装长度L1上中轴线的最大允许偏差ΔH Maximum permitted deviation ΔH from the central line in relation to L1							型号 Type			
	\uparrow	AB	Φ Φ A	α_G	\uparrow	AB	Φ Φ B	α_F	L1	250	500	750	1000		1500	2000	2500
20	0.1	0.4	20°	0.2	0.3	60°	2	0.1	0.2	0.2	0.3	0.4					20
22	0.1	0.4	15°	0.2	0.3	60°	2		0.2	0.2	0.3	0.4					22
24	0.1	0.4	15°	0.2	0.3	60°	2			0.2	0.3	0.4	0.5				24
25	0.1	0.5	15°	0.4	0.5	60°	2			0.2	0.3	0.4	0.5				25
26	0.1	0.5	15°	0.4	0.5	60°	3			0.2	0.3	0.4	0.5				26
27	0.1	0.5	15°	0.4	0.5	60°	3				0.3	0.4	0.5				27
29	0.1	0.5	15°	0.4	0.5	60°	3				0.3	0.4	0.5				29
31	0.2	0.5	15°	0.6	0.5	60°	3				0.3	0.4	0.5				31
32	0.2	0.5	15°	0.6	0.5	60°	3				0.3	0.4	0.5	0.7			32
33	0.2	0.5	12°	0.6	0.5	60°	3				0.3	0.4	0.5	0.7			33
34	0.2	0.5	10°	0.6	0.5	60°	3				0.3	0.4	0.5	0.7			34
36	0.3	0.5	10°	0.8	0.5	60°	3				0.3	0.4	0.5	0.7			36
38	0.3	0.5	10°	0.8	0.5	30°	3					0.4	0.5	0.7			38
40	0.3	0.5	10°	0.8	0.5	30°	3					0.4	0.5	0.7			40

10 润滑说明

润滑油(重负荷工业齿轮油)粘度牌号选用
【VG320(附件代号:UV32)】

环境温度/Ambient temperature °C	-20°C ~ +40°C
粘度牌号/Viscosity	VG320

注：1. 支撑结构轴端轴承采用脂润滑。
2. 上表中粘度牌号为40°C温度下的ISO-VG粘度。
3. 环境温度低于-10°C必须使用合成油。
4. 为保证产品寿命，实际使用中建议使用合成油。
5. 若环境温度超出上述范围，敬请垂询。

10 Lubrication

Lubrication viscosity (heavy industrial gear oil)
[VG20 (Code: UV32)]

Note: 1. The bearing on the support frame is lubricated by grease.
2. Above table viscosity is only for the temperature under 40°C.
3. Ambient temperature is -10°C, must use synthetic oil.
4. To make sure the long using life, we suggest to use synthetic oil.
5. If the ambient temperature is not in the range of table, please consult BONENG.

11 附件 (具体请垂询)

- 滚筒 (光筒、普通沟槽、特殊沟槽) /Drum (without grooves, with normal grooves, with special grooves)
- 滚筒支架/Drum support
- 底座/Base plate
- 电机/Motor
- 液压马达/Hydraulic motor
- 制动器/Brake
- 阀块/Valve
- 编码器/Encoder

11 Accessories (on request)

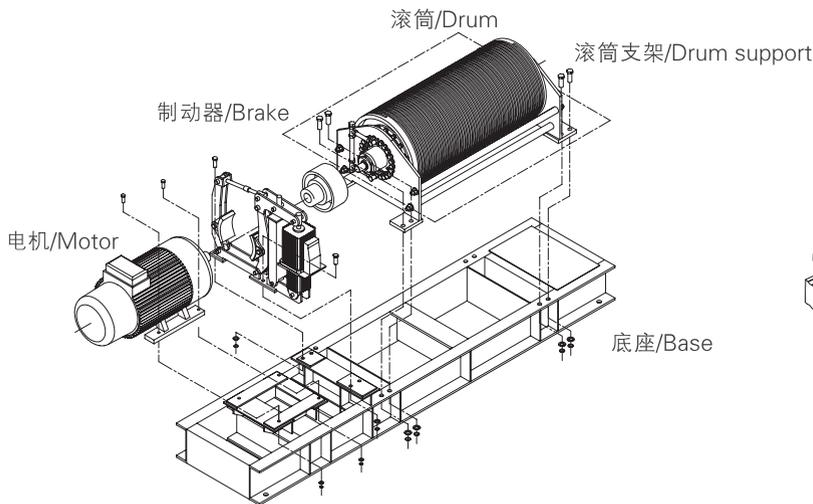

电机驱动总成
Integrated motor drive

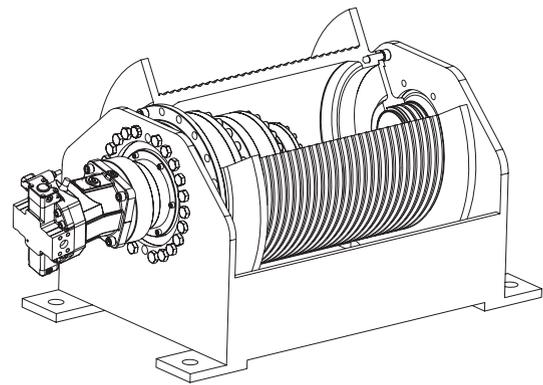

液压马达驱动总成
Integrated hydraulic motor drive

12 轴端中心孔:

12 Shaft end central hole:

轴端C型螺纹中心孔/C type screw central hole

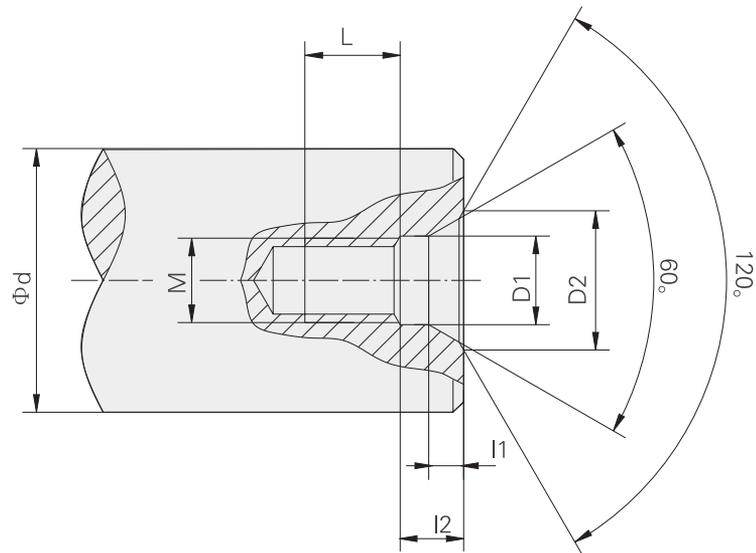

d	M	L	l2	l1	D1	D2
7 < d ≤ 10	M3	10	2.6	1.8	3.2	5.8
10 < d ≤ 13	M4	10	3.2	2.1	4.3	7.4
13 < d ≤ 16	M5	10	4	2.4	5.3	8.8
16 < d ≤ 21	M6	12	5	2.8	6.4	10.5
21 < d ≤ 24	M8	12	6	3.3	8.4	13.2
24 < d ≤ 30	M10	15	7.5	3.8	10.5	16.3
30 < d ≤ 38	M12	20	9.5	4.4	13	19.8
38 < d ≤ 50	M16	25	12	5.2	17	25.3
50 < d ≤ 85	M20	30	15	6.4	21	31.3
85 < d ≤ 130	M24	35	18	8	25	38
130 < d ≤ 225	M30	45	18	11	31	48

13 平键与键槽尺寸

13 Key and Keyway dimension

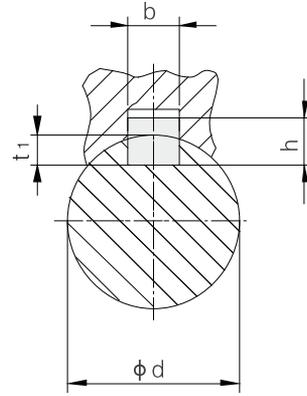
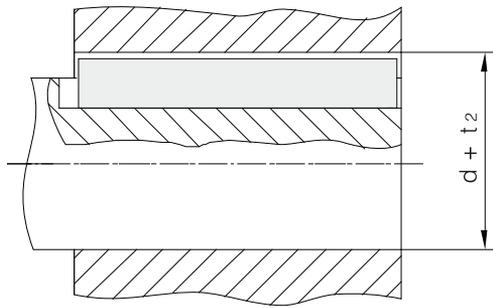

d	b	h	t ₁	d + t ₂
8 < d ≤ 10	3	3	1.8	d + 1.4
10 < d ≤ 12	4	4	2.5	d + 1.8
12 < d ≤ 17	5	5	3	d + 2.3
17 < d ≤ 22	6	6	3.5	d + 2.8
22 < d ≤ 30	8	7	4	d + 3.3
30 < d ≤ 38	10	8	5	d + 3.3
38 < d ≤ 44	12	8	5	d + 3.3
44 < d ≤ 50	14	9	5.5	d + 3.8
50 < d ≤ 58	16	10	6	d + 4.3
58 < d ≤ 65	18	11	7	d + 4.4
65 < d ≤ 75	20	12	7.5	d + 4.9
75 < d ≤ 85	22	14	9	d + 5.4
85 < d ≤ 95	25	14	9	d + 5.4
95 < d ≤ 110	28	16	10	d + 6.4
110 < d ≤ 130	32	18	11	d + 7.4
130 < d ≤ 150	36	20	12	d + 8.4
150 < d ≤ 170	40	22	13	d + 9.4
170 < d ≤ 200	45	25	15	d + 10.4
200 < d ≤ 230	50	28	17	d + 11.4
230 < d ≤ 260	56	32	20	d + 12.4

14 设计参数表

14 Parameter table

公司名称/Company name: _____
 地址/Address: _____
 联系人/Contact: _____
 电话/Tel: _____ 传真/Fax: _____
 应用/Application: _____ (举例/e.g. 岸桥/Quay crane, 克令吊/crane, 汽车吊/mobile crane, 船载起重等/ship offshore harbor cranes etc.)
 用于/Used for: _____ (举例/e.g. 主卷扬/Hoisting, 副卷扬/luffing, 牵引机/pulling winch)

工况概述/Operating condition	技术参数/Technical data
卷筒上拉力 (第一层) /Drum over pull (first rope layer) F1: [KN]	卷筒直径/Diameter of rope drum: [mm] (第一层/first rope layer)
最外层拉力/Top rope layer line pull F2: [KN]	钢丝绳直径/Rope diameter d: [mm]
最大测试载荷第 () 层/Max. testing loading number of rope layer F: [KN]	卷筒螺旋方向/Drum lead: <input type="checkbox"/> 右/right <input type="checkbox"/> 左/left <input type="checkbox"/> 普通绳槽/normal groove <input type="checkbox"/> 特殊绳槽/special groove <input type="checkbox"/> 光筒/grooveless
额定载荷下绳的速度/Rope speed with rated loading V: [m/min]	
空载时绳的速度/Rope speed without loading V: [m/min]	
卷筒上绳的数量/Rope numbers on the drum n:	
卷筒上总的绳拉力/Total line pull at drum F: [KN]	钢丝绳固定位置/Position of rope anchor: <input type="checkbox"/> 齿轮箱驱动端/drive side <input type="checkbox"/> 齿轮箱驱动端对面/opposite to drive
钢丝绳长度/Rope length Ls : [mm] (including 3 safety turns)	
速比/Ratio i:	卷筒长度或两档板间距/Length of drum between flanges L2 : [mm]

分类按/Classify as FEM1.001---ISO4301

设备分组/Drive unit group M: _____ 起重等级/The load spectrum L: _____ 工作时间等级/Running time classification T: _____

驱动单元/Drive unit

<input type="checkbox"/> 电机驱动/electric motor drive: 型号/Type: _____ 功率/Power P: _____ [KW] 额定转速/Rated speed n: _____ [rpm] 起动转矩/Starting torque MA: _____ [Nm] 极限转矩/Breakdown torque Tk: _____ [Nm] 起动时间/Starting time ED: _____ [%] 每小时起动/Starting per hour: _____	<input type="checkbox"/> 液压马达驱动/hydraulic motor drive 型号/Type: _____ 有效流量/Available oil flow q_v : _____ [L/min] 有效压力差/Available pressure difference ΔP : _____ [bar] 排量/Displacement V_g : _____ [cm ³]
---	--

制动/Brake

类型/Apply as <input type="checkbox"/> 驻车制动/parking brake <input type="checkbox"/> 工作制动/service braking	应用类型/Actuation <input type="checkbox"/> 液压/hydraulically 工作压力最小/Min. release pressure _____ [bar] 工作压力最大/Max. release pressure _____ [bar] <input type="checkbox"/> 电力/磁力 electric/ magnetic
--	---

目前供货范围 (具体请垂询) /Scope of supply (on request)

- | | |
|--|---|
| <input type="checkbox"/> 齿轮箱/gearbox | <input type="checkbox"/> 液压马达/hydraulic motor |
| <input type="checkbox"/> 滚筒支架/drum support | <input type="checkbox"/> 制动器/brake |
| <input type="checkbox"/> 滚筒/drum | <input type="checkbox"/> 阀块/valve |
| <input type="checkbox"/> 电机/motor | <input type="checkbox"/> 编码器/encoder |

备注和特殊要求/Remarks and special requests: _____